

OUTWARD OPENING

INWARD OPENING

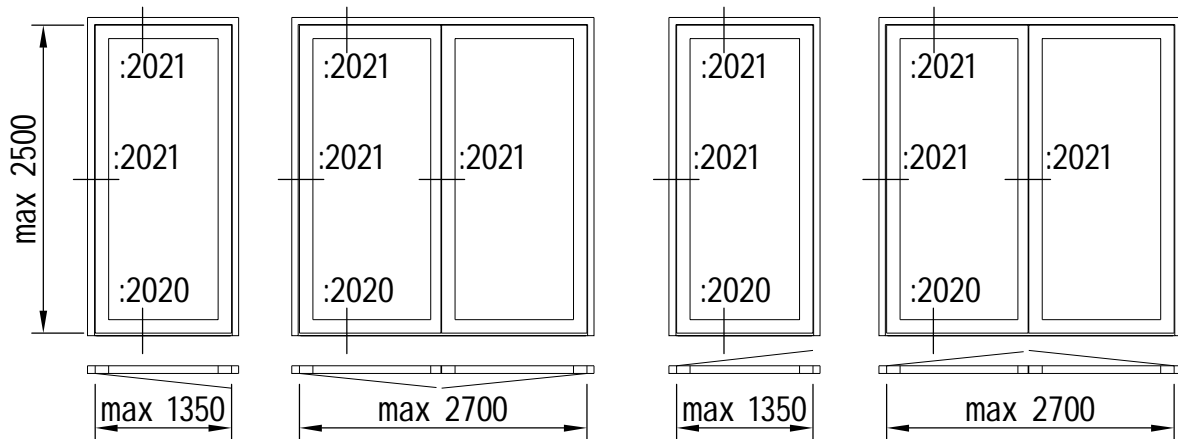

Max. dimension valid for door leaf!

SFB 2086 Plus

Air permeability class 2 and watertightness class 4A:

Classification and requirements according to SS-EN 12207 and SS-EN 12208.

Lock/striking plate:

Lock with at least one latch.

Striking plate Sapa P/N 14477, 14478 and Assa 1487-11.

Electrical striking plate only if higher gasket pressure can be accepted.

Hinge:

Dr. Hahn version 4 alt. concealed hinge (Sapa P/N 14090, 14091, 14059 and 14065)

Treshold:

Sapa P/N 86440 alt. 86436 for outward opening and Sapa P/N 86441 for inward opening doors.

Stop gasket:

Sapa P/N 18457 mounted continuously.

Generally: Doors can be designed as partitions with both side- and toplights under usage of rebate section Sapa P/N 86517. Partitions can even be designed with frame profiles Sapa P/N 86420, 86423 and 86424.

Attention! All connections between profiles have to be sealed accurately with joint glue Sapa P/N 12220.

REFERENCE:

Details, see drawing P2086-2020 and -2021