







	68280	68281	68282	68283	68290	68291	68292	68293
								
$I_x \text{ mm}^4$	$34 \times 10^4$	$125 \times 10^4$	$295 \times 10^4$	$676 \times 10^4$	$6 \times 10^4$	$33 \times 10^4$	$122 \times 10^4$	$282 \times 10^4$
$I_y \text{ mm}^4$	$20 \times 10^4$	$35 \times 10^4$	$49 \times 10^4$	$66 \times 10^4$	$10 \times 10^4$	$20 \times 10^4$	$35 \times 10^4$	$47 \times 10^4$
$W_x \text{ mm}^3$	$8 \times 10^3$	$21 \times 10^3$	$37 \times 10^3$	$65 \times 10^3$	$2 \times 10^3$	$8 \times 10^3$	$21 \times 10^3$	$36 \times 10^3$
Distance c in mm	$L_{\max}$ in mm							
800	2350	3600	4700	5800	1350	2300	3550	4650
1000	2200	3350	4450	5500	1300	2200	3350	4400
1200	2100	3200	4200	5250	1250	2100	3150	4150
1400	2050	3050	4000	5050	1250	2000	3050	3950
1600	2000	2950	3850	4900	1250	2000	2950	3800
1800	2000	2900	3750	4800	1250	1950	2850	3700
2000	2000	2800	3650	4700	1250	1950	2800	3600
2200		2800	3600	4600			2750	3550
2400		2750	3500	4500			2750	3450
2600		2750	3500	4450			2700	3450
2800		2700	3450	4400			2700	3400

**ASSUMPTIONS:**

- Beam on two supports
- Wind load 0,6 kN/m<sup>2</sup>
- Loaded with c mm
- Loaded area according to drawing
- Deflection L/300 and limited to 15 mm

k=Conversion factor for wind load  $q_v$  kN/m<sup>2</sup>

$$Lq_v = k * L_{\max}$$

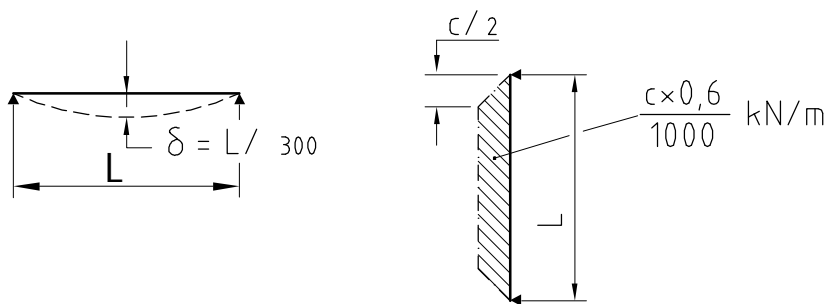

Windload $q_v$ kN/m <sup>2</sup>	k
0,4	1,13
0,5	1,05
0,6	1,0
0,7	0,95
0,8	0,91
0,9	0,88
1,0	0,84
1,2	0,80
1,4	0,76
1,6	0,72
1,8	0,69
2,0	0,67

**ATTENTION!**

Maximum deflection above a glass shall be assumed as 8mm.

<b>sapa:</b> <b>buildingsystem</b>	Data for estimated calculations of facade sections on two supports		<b>FACADE 5050</b>	
	-	07-03	<b>P5050-411</b>	